



ANSEL ANTONIO CITTERIO 2020

SOFAS

ANSEL | ANTONIO CITTERIO | 2020

SOFA

Structure in 316 stainless steel with epoxy-powder-coat finish in the following colors: white 100, wine red 405, khaki green 705, electropolished or burnished, matt titanium 710 or with embossed lacquered finish in white 300, sand 310, brick 320, sage green 330, terracotta 325, forest green 335, charcoal 350. Upholstered with water-repellent elastic webbing in the following colors: sand 9001, gray 9003, anthracite 9005, black 9009, salt and pepper 9017

Seat cushion in polyester fiber with insert in single-density crushproof material, covered in water repellent fabric

Backrest and armrest in solid iroko wood with natural finish, stained grey, stained brown. Supports and screws in 316 stainless steel, spacers in die-cast zama with transparent epoxy powder-coat finish

Backrest cushions / bolster in polyester fiber with water-repellent upholstery

Optional cushions in polyester fiber and water-repellent upholstery; upon request, with upcharge

Feet in cast aluminum with epoxy powder-coat finish in the following colors: white 100, wine red 405, khaki green 705, electropolished or burnished, matt titanium 710 or with embossed lacquered finish in white 300, sand 310, brick 320, sage green 330, terracotta 325, forest green 335, charcoal 350. Feet rest on tips made of thermoplastic material

Upholstery in removable fabric

Upholstery piping tailoring includes grosgrain piping that can be crafted in all the colors on the sample board

Cover in waterproof material; cover is upon request, with upcharge

COD. 0277A3

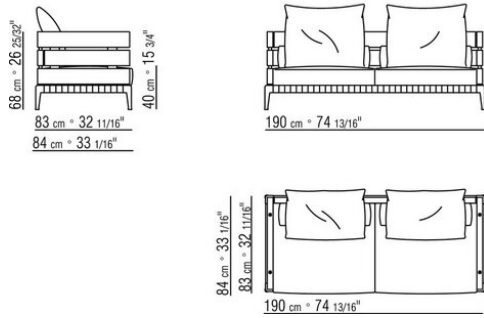

COD. 0277A5

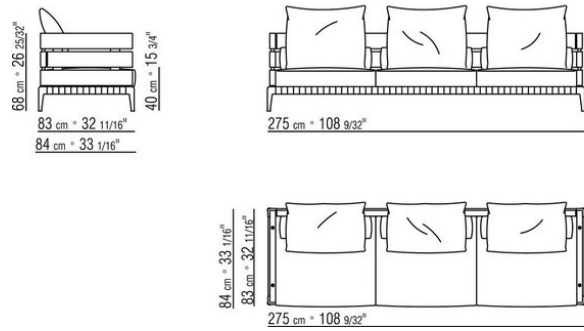

COD. 0277A7

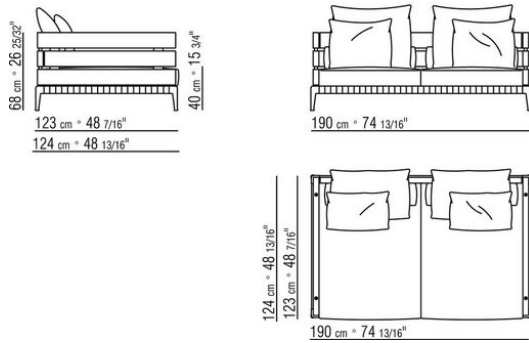

COD. 0277A9

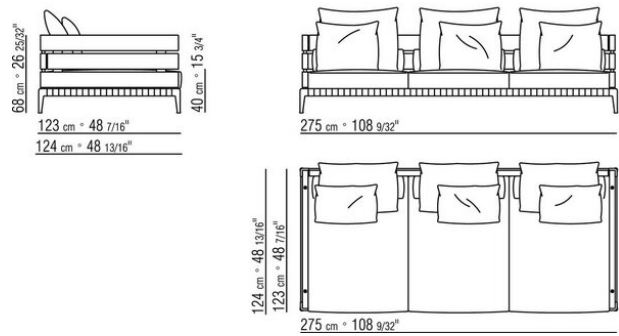

COD. 0277D5

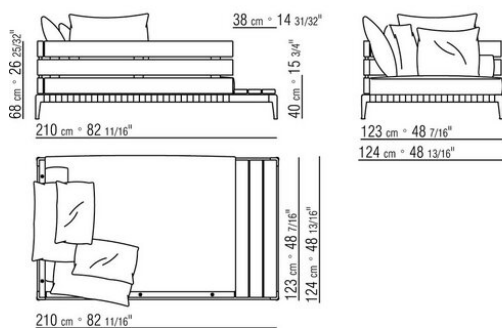

COD. 0277M7

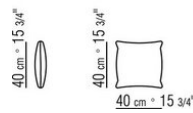

COD. 0277M8

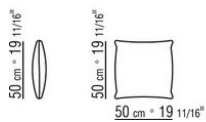

COD. 0277M9

