

Kress

Commercial



SAFETY AND OPERATING MANUAL

60V 11Ah Backpack CyberPack

KAC810

TABLE OF CONTENTS

Introduction.....	2
Component List.....	3
Product Safety.....	4
Operation Instructions.....	5
How to charge the battery.....	6
Storage.....	6
Transport.....	6
Maintenance and Service.....	6
Technical Data.....	7

INTRODUCTION

Dear Customer,

Thank you for buying this Kress Commercial product. We are dedicated to developing high quality products to meet your commercial landscaping requirements.

The Kress brand is synonymous with premium quality service. Over the years of your product's life, if you have any questions or concerns about your product, please contact your dealer or our Customer Service Team for assistance.

We are confident you will enjoy working with your Kress product for years to come.

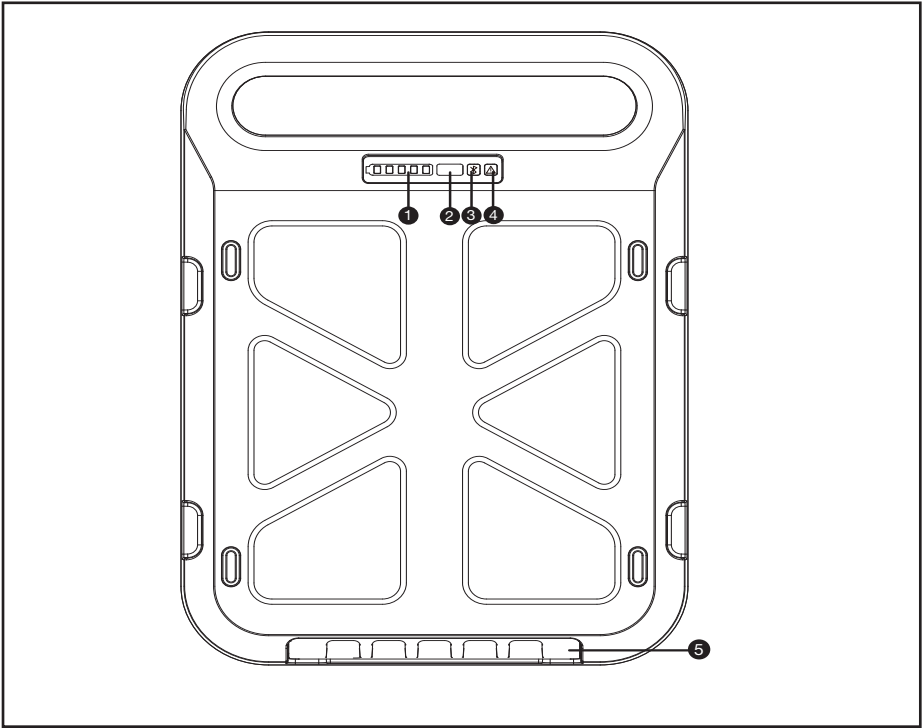

COMPONENT LIST

1. BATTERY INDICATOR LIGHT
2. POWER TEST BUTTON
3. BLUETOOTH INDICATOR LIGHT
4. FAULT INDICATOR LIGHT
5. DUST FILTER

PRODUCT SAFETY



WARNING Read all safety warnings and all instructions. *Failure to follow the warnings and instructions may result in electric shock, fire and/or serious injury.*

Carefully read the instructions for the safe operation of the machine.

Save all warnings and instructions for future reference.

Use battery pack for Kress cordless products only. Refer to the marking label and instruction manual provided with product.

SAFETY WARNINGS FOR BATTERY PACK

- a) Do not dismantle, open or shred cells or battery pack.
- b) Do not short-circuit a battery pack. Do not store battery packs haphazardly in a box or drawer where they may short-circuit each other or be short-circuited by conductive materials. When battery pack is not in use, keep it away from other metal objects, like paper clips, coins, keys, nails, screws or other small metal objects, that can make a connection from one terminal to another. Shorting the battery terminals together may cause burns or a fire.
- c) Do not expose battery pack to heat or fire. Avoid storage in direct sunlight.
- d) Do not subject battery pack to mechanical shock.
- e) In the event of battery leaking, do not allow the liquid to come into contact with the skin or eyes. If contact has been made, wash the affected area with copious amounts of water and seek medical advice.
- f) Keep battery pack clean and dry.
- g) Wipe the battery pack terminals with a clean dry cloth if they become dirty.
- h) Battery pack needs to be charged before use. Always refer to this instruction and use the correct charging procedure.
- i) Do not maintain battery pack on charge when not in use.
- j) After extended periods of storage, it may be necessary to charge and discharge the battery pack several times to obtain maximum performance.
- k) Recharge only with the charger specified by Kress. Do not use any charger other than that specifically provided for use with the equipment.
- l) Do not use any battery pack which is not designed for use with the equipment.
- m) Keep battery pack out of the reach of children.
- n) Retain the original product literature for future reference.
- o) Remove the battery from the equipment

when not in use.

- p) Dispose of properly.
- q) Do not mix cells of different manufacture, capacity, size or type within a device.
- r) Keep the battery away from microwaves and high pressure.
- s) **Warning!** Do not use non-rechargeable batteries.

ADDITIONAL SAFETY WARNING FOR COMMERCIAL BATTERY PACK





1. Use the battery pack for Kress Commercial cordless products only.
2. Use the battery pack only with KAC840 battery charger or additional battery chargers listed in operator's manual.
3. Use the battery pack only with KAC875A and KAC877A power station or additional power station listed in operator's manual.
4. In order to obtain the best performance, please pay attention to the following ambient temperature range, do not charge, use, or store in the case of exceeding the following temperature range:
 - a) Charging temperature range: -5°C~45°C
 - b) Discharge temperature range: -20°C~45°C
 - c) Storage temperature range: 5°C~25°C
5. To reduce the risk of electric shock, fire and explosion due to short circuits:
 - a) If the battery is exposed to rain during operation, please remove it from the product and let it dry indoors. Make sure it is completely dry before charging or re-using it.
 - b) Do not immerse the battery in water or other liquids.
 - c) Do not bridge battery terminals with wires or other metal objects.
 - d) The battery pack should be kept away from small conductive metal objects (such as paper clips, nails, coins, keys, etc.).
 - e) Store batteries indoors in a dry room.
 - f) Do not store the battery in a humid or corrosive environment, or in an environment that may cause its metal parts to corrode.
 - g) Protects batteries from exposure to corrosive substances such as gardening chemicals and deicing salts.
 - h) Never store batteries inside power tools.
 - i) When storing the battery, keep the battery with a charge between 40% to 60% (3 green lights illuminated).
 - j) If the battery pack needs to be shipped by air separately, the charge cannot exceed 30%
 - k) If storing the battery in the charger, disconnect the charger from the outlet.
 - l) Do not attempt to repair, open or disassemble the battery. There are no user-serviceable parts inside.

m) To reduce the risk of personal injury from accidental activation, always remove the battery before assembling, transporting, adjusting, cleaning, servicing, or storing the power tool.

6. A battery fire is dangerous. To reduce the risk of serious personal injury and property damage in the event of a fire:
 - a) Evacuate the area. Fires can spread quickly. Keep away from any generated gas and fumes and keep a safe distance.
 - b) Contact the fire department.
 - c) While water can be used to extinguish battery fires, it is best to use a multi-purpose dry chemical fire extinguisher.
 - d) Please consult the fire department for proper disposal of burned batteries.
7. Leaking battery fluid can cause skin and eye irritation or chemical burns.
 - a) Avoid contact with skin and eyes.
 - b) If liquid gets in eyes: Do not rub. Flush open eyes with water for at least 15 minutes, and seek medical advice.
 - c) In case of accidental contact, wash the contact area immediately and thoroughly with mild soap and water.
 - d) Use an inert absorbent such as sand on spilled liquid.

technician for help.

SYMBOLS

 Li-Ion  Li-Ion	<p>Li-Ion battery This product has been marked with a symbol relating to 'separate collection' for all battery packs and battery pack. It will then be recycled or dismantled in order to reduce the impact on the environment. Battery packs can be hazardous for the environment and for human health since they contain hazardous substances.</p>
	<p>Do not burn</p>
	<p>Batteries may enter water cycle if disposed improperly, which can be hazardous for ecosystem. Do not dispose of waste batteries as unsorted municipal waste.</p>
	<p>RCM marking</p>

USER MANUAL REQUIREMENTS FOR WIRELESS PRODUCT

- a) Operation of this device is subject to the following two conditions:
 - (1) This device may not cause harmful interference, and
 - (2) this device must accept any interference received, including interference that may cause undesired operation.
- b) Caution: Changes or modifications to this unit not expressly approved by the party responsible for compliance could void the user's authority to operate the equipment.
- c) NOTE: This equipment generates, uses and can radiate radio frequency energy and, if not installed and used in accordance with the instructions, may cause harmful interference to radio communications. However, there is no guarantee that interference will not occur in a particular installation. If this equipment does cause harmful interference to radio or television reception, which can be determined by turning the equipment off and on, the user is encouraged to try to correct the interference by one or more of the following measures:
 - Reorient or relocate the receiving antenna.
 - Increase the separation between the equipment and receiver.
 - Connect the equipment into an outlet on a circuit different from that to which the receiver is connected.
 - Consult the dealer or an experienced radio/TV

ABN: Australian Business Number. By this number, business information such as entity type, status, business location etc. can be found at website <http://abr.business.gov.au>.
 ABN of Positec Australia Pty Limited is 14 101 682 357

OPERATION INSTRUCTIONS

Recommendations for optimal handling of the battery

Note:

1. Your battery pack is partly charged and needs to be fully charged before first use. To ensure full capacity of the battery, completely charge the battery in the battery charger before using your battery in the power tool for the first time.
2. A battery pack will slowly lose its charge when kept out of the charger or left in an unplugged charger for a long time. It may need to be recharged before use.







The CyberPack can be used with a backpack, please refer to the backpack manual for details.

When over-discharge, over-charge, over-temperature and low-temperature faults occur while the battery pack is being charged on the charger or used on the machine, the user will receive a fault prompt, and the charger or the machine will stop

charging or working.

The Li-Ion battery can be charged at any time without reducing its service life. Interrupting the charging procedure does not damage the battery.

The battery level can be determined from the battery indicator light by pressing the power test button. Before starting or after use, press the power test button on the battery pack to check the battery capacity.

Remarks	LED light	Battery condition
Five green lights are illuminated.		$80\% \leq \text{Power level} \leq 100\%$
Four green lights are illuminated.		$60\% \leq \text{Power level} < 80\%$
Three green lights are illuminated.		$40\% \leq \text{Power level} < 60\%$
Two green lights are illuminated.		$20\% \leq \text{Power level} < 40\%$
One green light is illuminated.		$10\% \leq \text{Power level} < 20\%$
One green light is flashing.		$0\% \leq \text{Power level} < 10\%$

You can see the relevant status of the battery through the status of the Bluetooth indicator light and the fault indicator light.

Remarks	Battery condition
Bluetooth indicator light is illuminated.	Bluetooth is connected.
Bluetooth indicator light is not illuminated.	Bluetooth is not connected.
Fault indicator light is illuminated.	Battery failure, prohibit charging and discharging.
Fault indicator light is not illuminated.	It is normal.

When the battery pack fails, the fault indicator will light up, and you can view the specific fault cause and solution through the App.

HOW TO CHARGE THE BATTERY

Refer to the instruction manual for charger.

STORAGE

Store the battery only within an ambient temperature range between 5~25°C.

When kept out of the charger or left in an unplugged charger for a long time, the battery still reaches a relatively high level.

A significantly reduced working period after charging indicates that the battery is used and must be replaced.

TRANSPORT

The contained Li-Ion batteries are subject to the dangerous goods legislation requirements. The user can transport the batteries by road without additional requirements.

Dispatch batteries only when the battery housing is undamaged. Pack up the batteries in such a manner that cannot move around in the packaging.

MAINTENANCE AND SERVICE

Occasionally clean the venting slots of the battery using a soft, clean and dry brush.

When the dust filter on the battery is blocked, it needs to be removed and rinsed with water. After drying, put the dust filter back into the battery. To protect the battery, if the dust filter is damaged, please replace it in time. (See Fig. A)

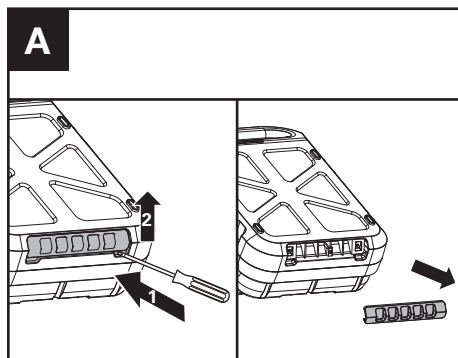

When the battery is no longer operative, please refer to an authorized after-sales service agent for Kress power tools.

TECHNICAL DATA

	KAC810
Rated voltage	60 V  MAX*
Battery capacity	11.0 Ah
Recommended Ambient Temperature for Charging	-5~45 °C
Optimum Storage Temperature in Use	5~25 °C
Battery Weight	7.7 kg
Degree of protection	IPX5
Frequency bands for Bluetooth	2400-2483.5 MHz
Maximum Transmitted Power for Bluetooth	8 dBm

* Voltage measured without workload. Initial battery voltage reaches maximum of 60 volts. Nominal voltage is 54 volts.

Positec Australia Pty Limited
10 Corporate Blvd Bayswater , VIC 3153, Australia



Copyright © 2023, Positec. All Rights Reserved.
AR03060700