

**FLEXFORM**



**WING** ANTONIO CITTERIO 2014

SOFAS

---

**FLEXFORM** Spa

Via Einaudi 23/25 20821 Meda (MB) Italy | Tel. +39 0362 3991 | [info@flexform.it](mailto:info@flexform.it) | [www.flexform.it](http://www.flexform.it)

---

## WING | ANTONIO CITTERIO | 2014

**Gestell** Metallrahmen mit Kernleder bezogen in den Farben: grau (5003), schwarz (5005), olivgrün (5006), rotbraun (5008), sand (5001), tabak (5015), testa di moro (5004), testa di moro dunkel (5013). Wildleder in den Farben: olivgrün (6003), testa di moro (6004), schwarz (6005), sand (6001). Auflage mit Polyurethanpolsterung

**Sitzkissen:** Füllung aus sterilisierten Gänsedaunen (zertifiziert Assopiuma, "goldenes Etikett") mit Kern aus formbeständigem Material

**Rückenlehne und Armlehne:** aus Metall und Sperrholz mit Polsterung aus Pu-

Schaum und Dacron

**Füsse/Rückenlehne** in den folgenden Ausführungen: satiniert, chrom, schwarz chrom, brüniert, anthrazit glänzend. Beine mit Kunststoffgleitern

**Lose Kissen** Füllung aus sterilisierten Gänsedaunen (zertifiziert Assopiuma, "goldenes Etikett"). Die zusätzlichen Kissen sind auf Anfrage gegen Aufpreis erhältlich

**Bezug:** Stoffbezug oder Lederbezug, beide Versionen abziehbar

COD. 020602

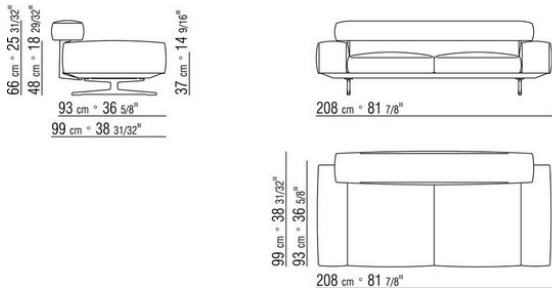

COD. 020603

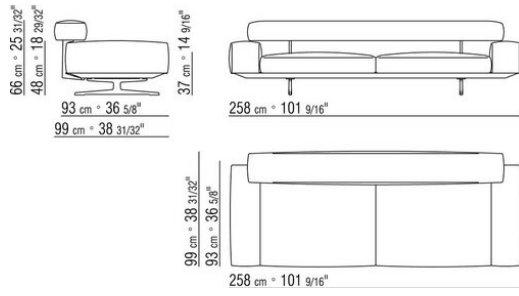

COD. 020604

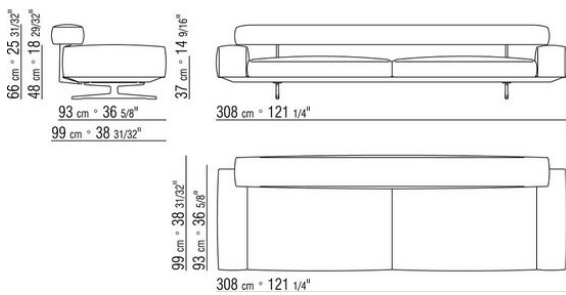

COD. 020607

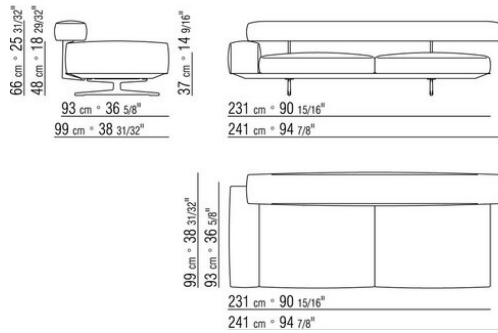

COD. 020609

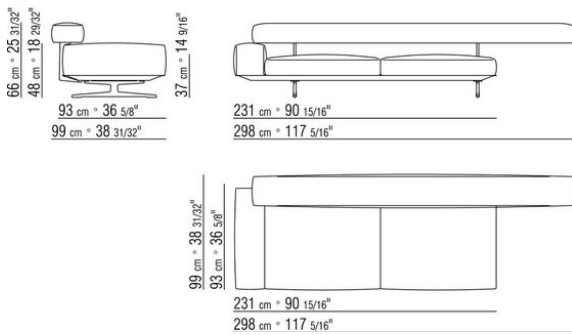

COD. 020611

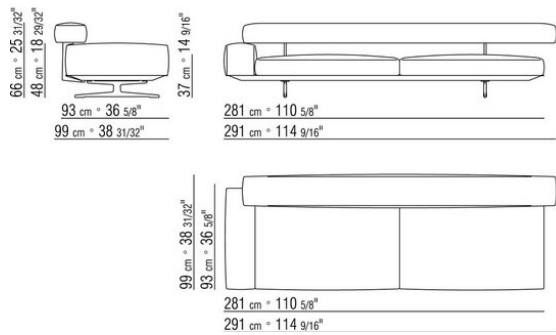

COD. 020613

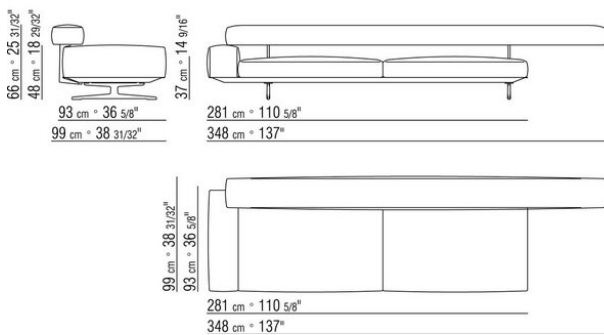

COD. 020615

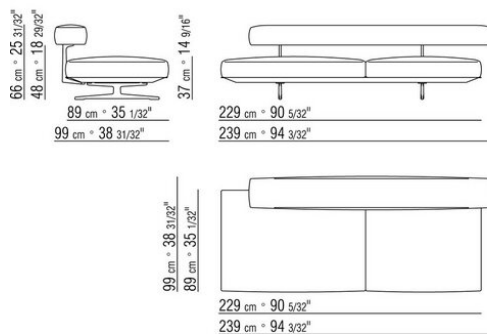

COD. 020619

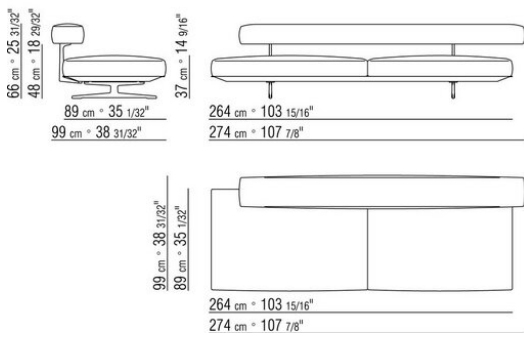

COD. 020617

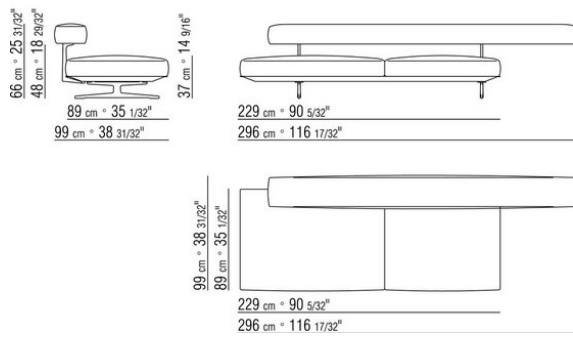

COD. 020621

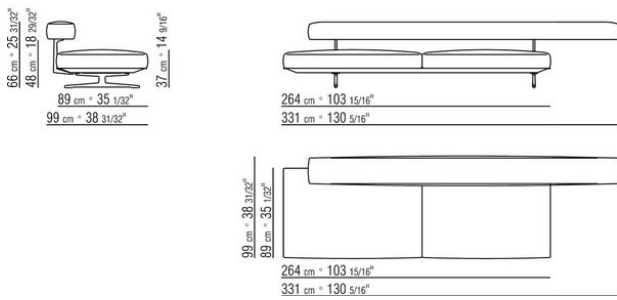

COD. 020658

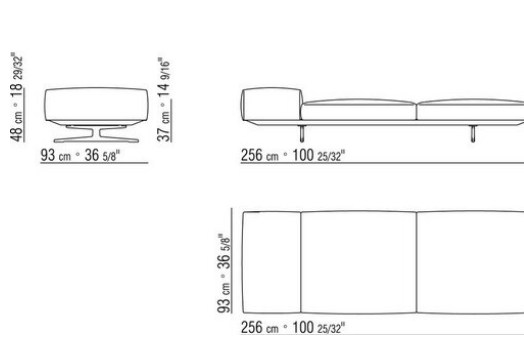

COD. 020633

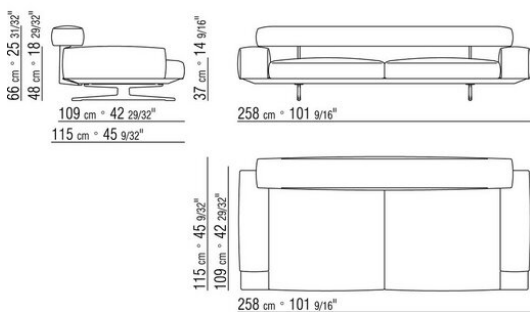

COD. 020634

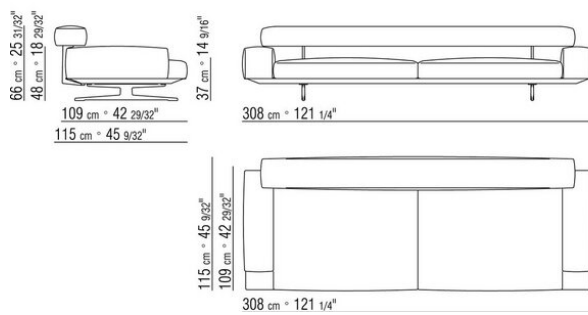

COD. 020640

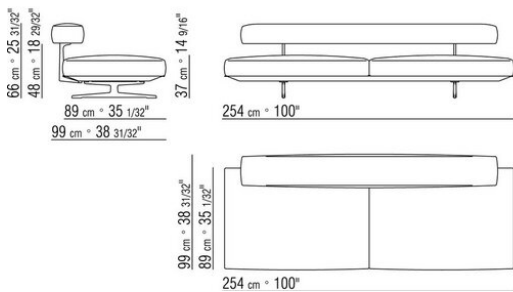

COD. 020643

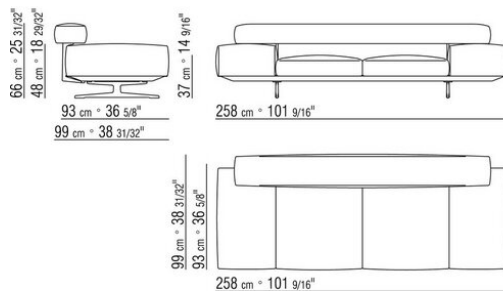

COD. 020644

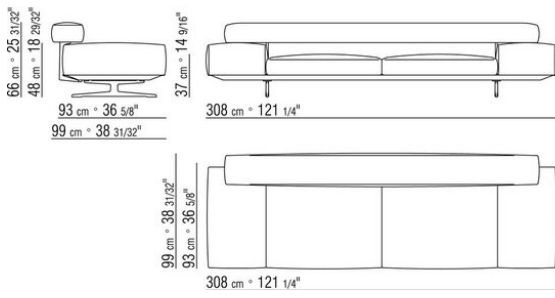

COD. 020647

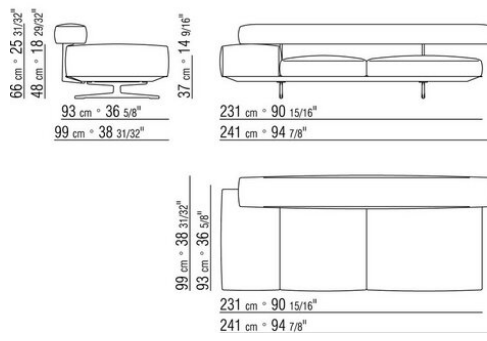

COD. 020651

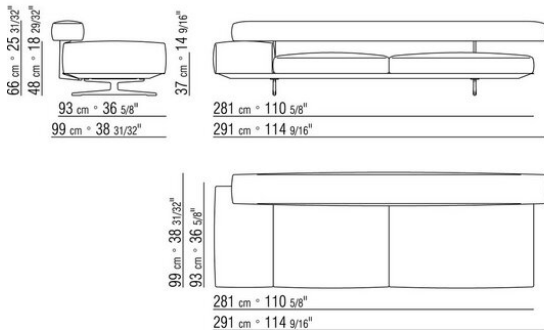

COD. 020649

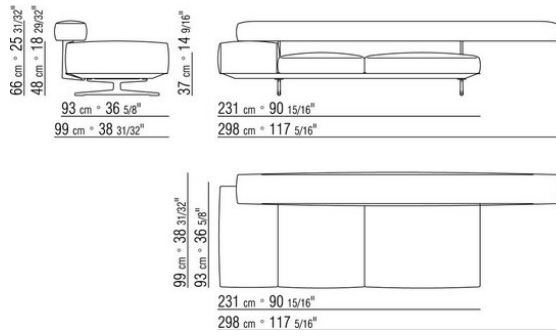

COD. 020653

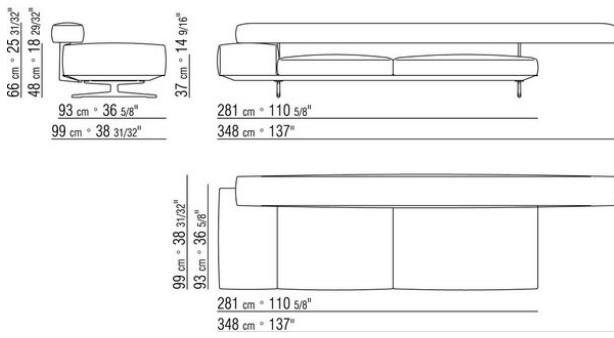

COD. 020697

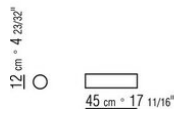

COD. 020698

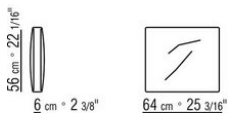

COD. 020699

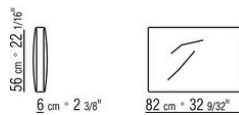

0206XA

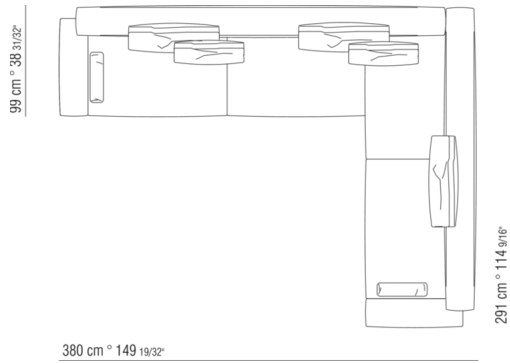

- N.1 COD.020613 - ECKELEMENT / ENDELEMENT / SCHMALE ARMLEHNE L CM.348 x99
- N.1 COD.020610 - ECKELEMENT / ENDELEMENT / SCHMALE ARMLEHNE R CM.291 x99
- N.2 COD.020697 - ROLLE Ø 12 CM.45 x
- N.2 COD.020698 - KISSEN CM.64 x56
- N.3 COD.020699 - KISSEN CM.82 x56

0206XB

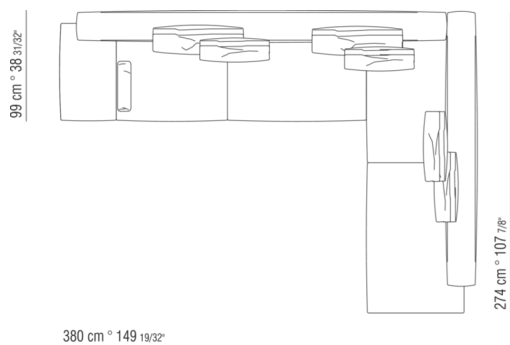

- N.1 COD.020653 - ECKELEMENT / ENDELEMENT /BREITE ARMLEHNE L CM.348 x99
- N.1 COD.020618 - ELEMENT/ECKELEMENT CM.274 x99
- N.1 COD.020697 - ROLLE Ø 12 CM.45 x
- N.4 COD.020698 - KISSEN CM.64 x56
- N.2 COD.020699 - KISSEN CM.82 x56